



core white  
BLEACHING LIGHT

core white

**G.Comm S.r.l.**

Via Donizetti, 22

20872 Cornate d'Adda (MB) Italy

T +39 039 60 60 420

F +39 039 69 26 991

info@gcomm-online.com

www.gcomm-online.com





FEATURES



TECHNIC

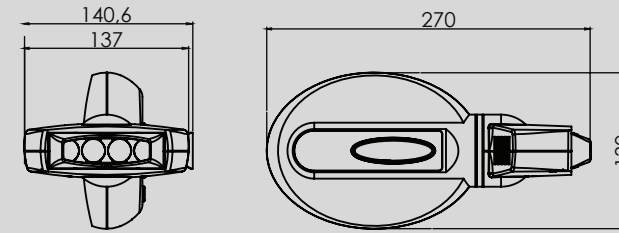

TECHNICAL FEATURES

Weight: approx. 800g  
 Power supply: 17-24Vac  
 Maximum power consumption: 30VA  
 Current consumption: 1.5A  
 Light pattern: 80x20mm  
 Light source: 4LEDs (3.5W each)  
 Emission spectrum: 420-480nm  
 Maximum light power emitted: 2000mW  
 Maximum distance from patient: 10cm

A LONG HISTORY OF QUALITY AND VERSATILITY

CoreWhite is a bleaching system for tooth whitening implemented for POLARIS or on a cart system, to grant a 360° range of motion. The cart system is robust made in steel and dust painted so as to be durable. Easy to clean does not suffer any major aggressive cleaning detergent.

LEDS SYSTEM

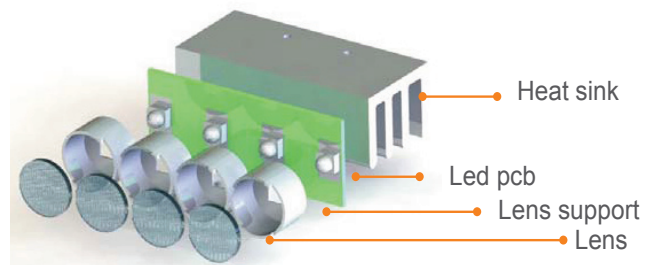

The optical system of Core White is made as shown in the figure. The light beams emitted by each of 4 LED sources are focused with special lenses and concentrated into one rectangular and homogeneous pattern. Special filters are used to eliminate I.R. on luminous pattern.

FOUR DIFFERENT WORKING PROGRAMS



1-20min TREATMENT TIME ADJUSTABLE

Cart application

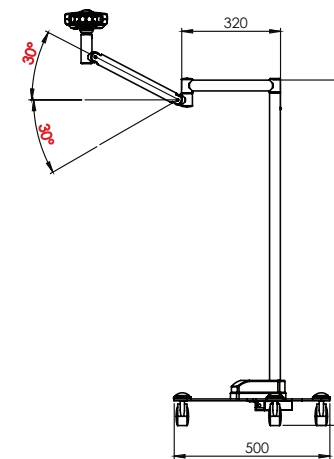
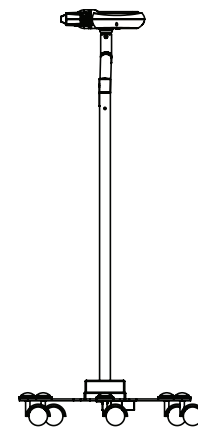

Polaris application

